

- Unequal flute spacing.
- Centre cutting.
- Single tool for both roughing and finishing operations requiring fewer setups.
- Standard items listed. Additional styles and coatings made-to-order.

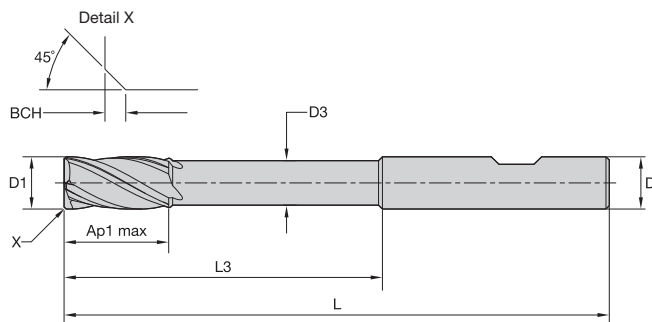
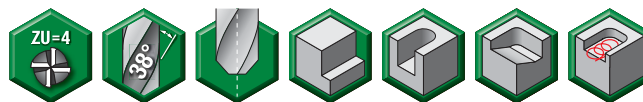

End Mill Tolerances

D1	tolerance e8	D	tolerance h6 + / -
≤ 3	-0,014/-0,028	≤ 3	0/-0,006
> 3-6	-0,020/-0,038	> 3-6	0/-0,008
> 6-10	-0,025/-0,047	> 6-10	0/-0,009
> 10-18	-0,032/-0,059	> 10-18	0/-0,011
> 18-30	-0,040/-0,073	> 18-30	0/-0,013

■ Series 47N6 • VariMill • Extended Reach with Neck

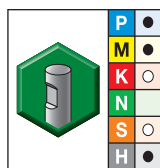

grade TiAlN-LW  
TiAlN

- first choice
- alternate choice

order #	catalogue #	D1	D	D3	length of cut Ap1 max	L3	length L	BCH
4067705	47N606002LW	6,0	6	5,50	12,00	42,00	100	0,40
4067706	47N608003LW	8,0	8	7,30	16,00	62,00	100	0,40
4067707	47N610004LW	10,0	10	9,10	20,00	60,00	100	0,50
4067708	47N612005LW	12,0	12	11,00	24,00	73,00	125	0,50
4067709	47N616006LW	16,0	16	14,56	32,00	100,00	150	0,50
4067710	47N620007LW	20,0	20	18,20	40,00	98,00	175	0,50

High-Performance Solid Carbide End Mills