

- Centre cutting.
- Flat shallow profile.
- Standard items listed. Additional styles and coatings made-to-order.

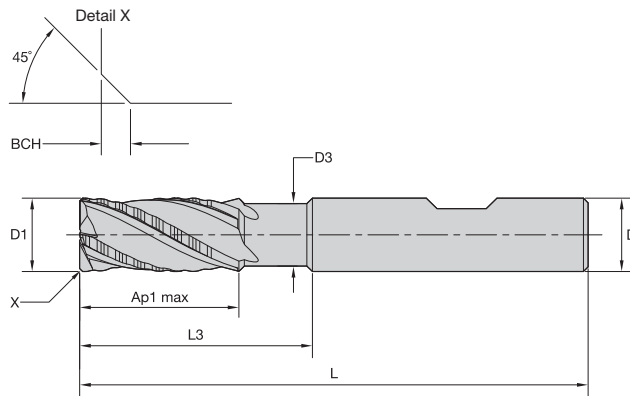
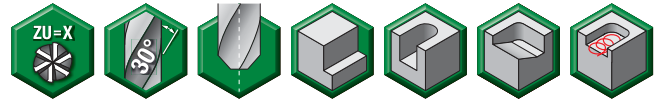

End Mill Tolerances

D1	tolerance d11	D	tolerance h6 + / -
≤ 3	-0,020/-0,080	≤ 3	0/-0,006
> 3-6	-0,030/-0,105	> 3-6	0/-0,008
> 6-10	-0,040/-0,130	> 6-10	0/-0,009
> 10-18	-0,050/-0,160	> 10-18	0/-0,011
> 18-30	-0,065/-0,195	> 18-30	0/-0,013

■ Series 49N6 • With Neck

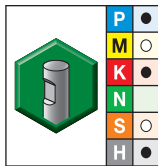

grade AlTiN-MW
AlTiN

- first choice
- alternate choice

order #	catalogue #	D1	D	D3	length of cut Ap1 max	L3	length L	BCH	ZU
3474583	49N604002MW	4,0	6	—	8,00	8,00	57	0,30	3
3474584	49N605002MW	5,0	6	—	13,00	13,00	57	0,30	3
3474585	49N606002MW	6,0	6	6	13,00	21,00	57	0,30	3
3474587	49N608003MW	8,0	8	8	16,00	27,00	63	0,30	3
3474589	49N610004MW	10,0	10	10	22,00	32,00	72	0,50	4
3474591	49N612005MW	12,0	12	11	26,00	38,00	83	0,50	4
3474593	49N614014MW	14,0	14	13	26,00	38,00	83	0,50	4
3474594	49N616006MW	16,0	16	15	32,00	44,00	92	0,50	4
3474595	49N618018MW	18,0	18	17	32,00	44,00	92	0,50	4
3474596	49N620007MW	20,0	20	19	38,00	54,00	104	0,50	4
3474597	49N625008MW	25,0	25	24	45,00	65,00	121	0,50	5