

# High-Performance Solid Carbide End Mills • Aluminium

Series 024101

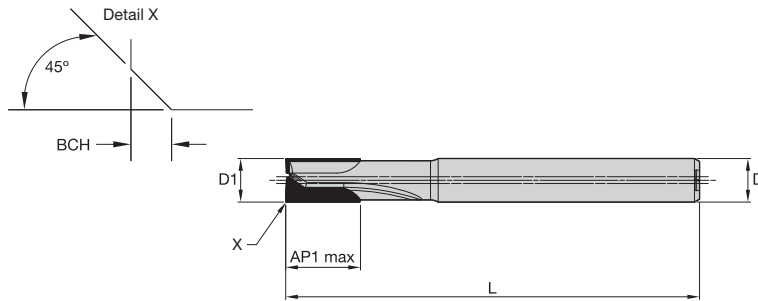

- Centre cutting.
- PCD tipped.
- Through coolant.
- Standard items listed. Additional styles and coatings made-to-order.



End Mill Tolerances

D1	tolerance e8	D	tolerance h6 + / -
All	+0,03/-0,03	≤ 3	0/0,006
		> 3-6	0/0,008
		> 6-10	0/0,009
		> 10-18	0/0,011
		> 18-30	0/0,013

## Series 024101

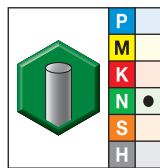

grade UNCOATED Diamond

- first choice
- alternate choice

order #	catalogue #	D1	D	length of cut Ap1 max	length L	BCH
2333086	024101-000060	6,0	6	10,00	57	0,08
2333087	024101-000080	8,0	8	15,00	63	0,10
2333088	024101-000100	10,0	10	15,00	72	0,12

High-Performance Solid Carbide End Mills