

High-Performance Solid Carbide End Mills • Aluminium

Series 4909

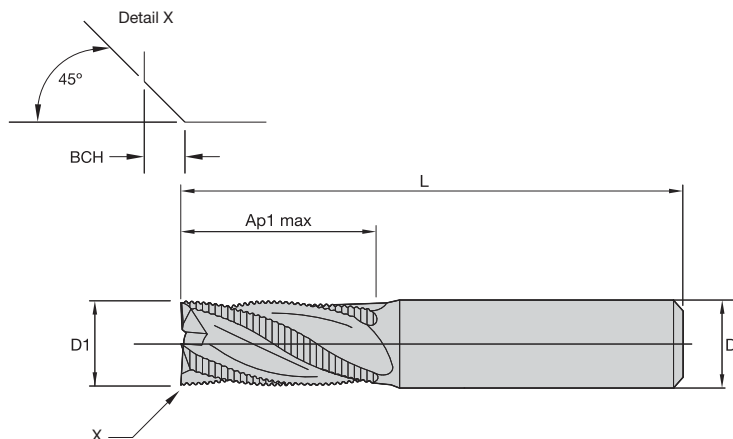

- Centre cutting.
- Coarse pitch.
- Standard items listed. Additional styles and coatings made-to-order.

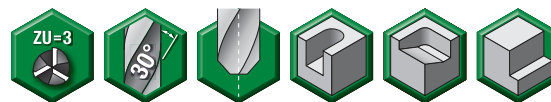

End Mill Tolerances

D1	tolerance d11	D	tolerance h6 + / -
≤ 3	-0,020/-0,080	≤ 3	0/0,006
> 3-6	-0,030/-0,105	> 3-6	0/0,008
> 6-10	-0,040/-0,130	> 6-10	0/0,009
> 10-18	-0,050/-0,160	> 10-18	0/0,011
> 18-30	-0,065/-0,195	> 18-30	0/0,013

Series 4909

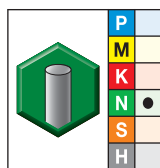

grade UNCOATED

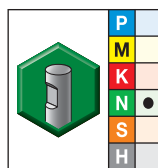

grade UNCOATED-WW

- first choice
- alternate choice

order #	catalogue #	order #	catalogue #	D1	D	length of cut Ap1 max	length L	BCH
1657125	490906002..	1657126	490906002WW	6,0	6	13,00	57	0,06
1657127	490908003..	1657128	490908003WW	8,0	8	16,00	63	0,06
1657129	490910004..	1657131	490910004WW	10,0	10	22,00	72	0,06
1657132	490912005..	1657134	490912005WW	12,0	12	26,00	83	1,00
1657136	490914014..	1657137	490914014WW	14,0	14	26,00	83	1,00
1657138	490916006..	1657140	490916006WW	16,0	16	32,00	92	1,00
1657142	490918018..	1657143	490918018WW	18,0	18	32,00	92	1,00
1657144	490920007..	1657145	490920007WW	20,0	20	38,00	104	1,00
1657146	490925008..	1657148	490925008WW	25,0	25	45,00	121	1,00

High-Performance Solid Carbide End Mills