

# General Purpose Solid Carbide End Mills • Roughing/Finishing

Series 2819 • VariMill™ GP

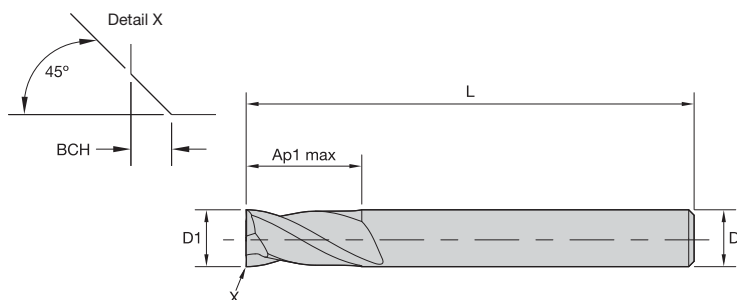

- Centre cutting.
- Chamfered corners.
- Standard items listed. Additional styles and coatings made-to-order.

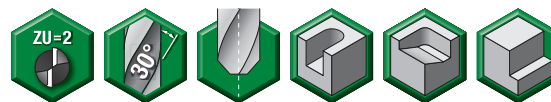

End Mill Tolerances

D1	tolerance e8	D	tolerance h6 + / -
≤ 3	-0,014/-0,028	≤ 3	0/0,006
> 3-6	-0,020/-0,038	> 3-6	0/0,008
> 6-10	-0,025/-0,047	> 6-10	0/0,009
> 10-18	-0,032/-0,059	> 10-18	0/0,011
> 18-30	-0,040/-0,073	> 18-30	0/0,013

## Series 2819 • VariMill GP

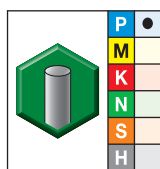

grade UNCOATED

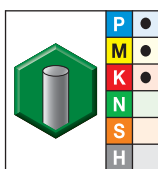

grade TiAlN  
TiAlN

- first choice
- alternate choice

order #	catalogue #	order #	catalogue #	D1	D	length of cut Ap1 max	length L	BCH
5877617	28190300T007	5877603	28190300T007	3,0	3	8,00	50	—
5877618	28190400T008	5877604	28190400T008	4,0	4	8,00	50	0,10
5877619	28190500T010	5877605	28190500T010	5,0	5	10,00	50	0,10
5877620	28190600T010	5877606	28190600T010	6,0	6	10,00	57	0,10
5877621	28190700T013	5877607	28190700T013	7,0	7	13,00	60	0,10
5877622	28190800T016	5877608	28190800T016	8,0	8	16,00	63	0,20
5877623	28190900T016	5877609	28190900T016	9,0	9	16,00	67	0,20
5877624	28191000T019	5877610	28191000T019	10,0	10	19,00	72	0,20
5877625	28191200T022	5877611	28191200T022	12,0	12	22,00	83	0,30
5877626	28191400T022	5877612	28191400T022	14,0	14	22,00	83	0,30
5877627	28191500T026	5877613	28191500T026	15,0	15	26,00	92	0,30
5877628	28191600T026	5877614	28191600T026	16,0	16	26,00	92	0,30
5877629	28191800T026	5877615	28191800T026	18,0	18	26,00	92	0,30
5877630	28192000T032	5877616	28192000T032	20,0	20	32,00	104	0,30

NOTE: For application data, please see page P23.

General Purpose Solid Carbide End Mills