

High-Performance High-Speed Steel (HSS-E/PM) • Roughing

Series 664W 660W 661W • WavCut I™

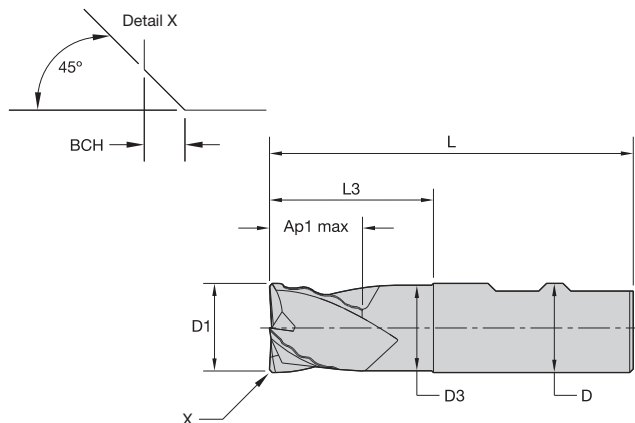

- Centre cutting.
- Standard items listed. Additional styles and coatings made-to-order.



End Mill Tolerances

| D1 | tolerance | D | tolerance h6 +/- |
|-----|-------------|---------|------------------|
| All | +0,05/-0,05 | ≤ 3 | 0/0,006 |
| | | > 3-6 | 0/0,008 |
| | | > 6-10 | 0/0,009 |
| | | > 10-18 | 0/0,011 |
| | | > 18-30 | 0/0,013 |
| | | > 30-50 | 0/0,016 |

Series 664W 660W 661W • WavCut I

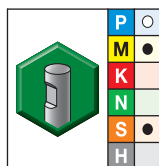

- first choice
- alternate choice

grade UNCOATED-WW

| order # | catalogue # | D1 | D | D3 | length of cut Ap1 max | L3 | length L | BCH | ZU |
|---------|-------------|------|----|----|-----------------------|--------|----------|------|----|
| 3871691 | 664W25008WW | 25,0 | 25 | 23 | 26,00 | 46,00 | 102 | 1,00 | 5 |
| 3871692 | 660W25008WW | 25,0 | 25 | 23 | 45,00 | 65,00 | 121 | 1,00 | 5 |
| 3871833 | 661W25008WW | 25,0 | 25 | 23 | 90,00 | 110,00 | 166 | 1,00 | 6 |
| 3871834 | 664W32009WW | 32,0 | 32 | 30 | 32,00 | 52,00 | 112 | 1,00 | 6 |
| 3871835 | 660W32009WW | 32,0 | 32 | 30 | 53,00 | 73,00 | 133 | 1,00 | 6 |
| 3871836 | 661W32009WW | 32,0 | 32 | 30 | 100,00 | 110,00 | 170 | 1,00 | 6 |
| 3871837 | 664W40009WW | 40,0 | 32 | — | 38,00 | 58,00 | 118 | 1,00 | 6 |
| 3871838 | 660W40009WW | 40,0 | 32 | — | 56,00 | 65,00 | 125 | 1,00 | 6 |
| 3871839 | 661W40009WW | 40,0 | 32 | — | 100,00 | 110,00 | 170 | 1,00 | 6 |
| 3871840 | 664W50000WW | 50,0 | 50 | 47 | 40,00 | 60,00 | 140 | 1,00 | 6 |
| 3871841 | 660W50000WW | 50,0 | 50 | 47 | 75,00 | 95,00 | 175 | 1,00 | 6 |
| 3871842 | 661W50000WW | 50,0 | 50 | 47 | 110,00 | 130,00 | 210 | 1,00 | 8 |

NOTE: For application data, please see page Q10.

High-Performance High-Speed Steel (HSS-E/PM)