

# High-Performance High-Speed Steel (HSS-E/PM) • Roughing

Series 6N70

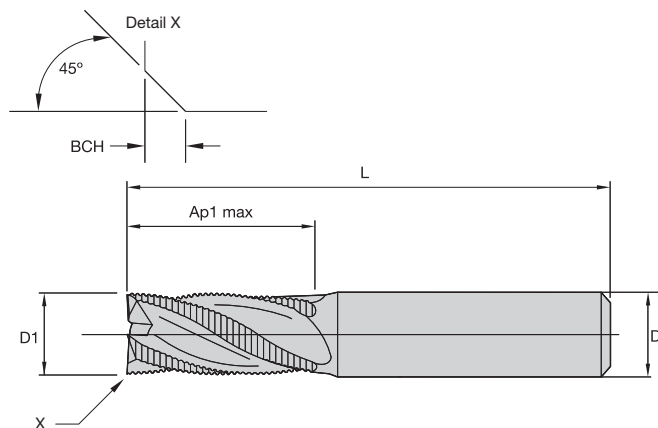

- Centre cutting.
- Flat shallow pitch.
- Standard items listed. Additional styles and coatings made-to-order.



End Mill Tolerances

D1	tolerance	D	tolerance h6 + / -
All	+0,12/-0,12	≤ 3	0/0,006
		> 3-6	0/0,008
		> 6-10	0/0,009
		> 10-18	0/0,011
		> 18-30	0/0,013

## Series 6N70

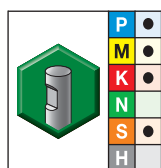
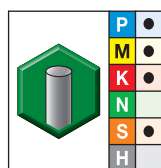

- first choice
- alternate choice

grade TiAlN-LT TiAlN		grade TiAlN-LW TiAlN		D1	D	length of cut Ap1 max	length L	BCH	ZU
order #	catalogue #	order #	catalogue #						
2990812	6N7006002LT	1660596	6N7006002LW	6,0	6	13,00	57	0,25	4
2992083	6N7008004LT	1660598	6N7008004LW	8,0	10	19,00	69	0,25	4
1981089	6N7010004LT	1660600	6N7010004LW	10,0	10	22,00	72	0,25	4
1981090	6N7012005LT	1660602	6N7012005LW	12,0	12	26,00	83	0,35	4
3078687	6N7014005LT	—	—	14,0	12	26,00	83	—	4
—	—	1660604	6N7014005LW	14,0	12	26,00	83	0,35	4
1717017	6N7016006LT	1660606	6N7016006LW	16,0	16	32,00	92	0,35	4
3077681	6N7018006LT	—	—	18,0	16	32,00	92	—	4
—	—	1660608	6N7018006LW	18,0	16	32,00	92	0,35	4
1716039	6N7020007LT	1660610	6N7020007LW	20,0	20	38,00	104	0,35	4
2992087	6N7025008LT	1660612	6N7025008LW	25,0	25	45,00	121	0,50	4
3078692	6N7032009LT	—	—	32,0	20	53,00	133	—	6
—	—	1660614	6N7032009LW	32,0	32	53,00	133	0,50	6

NOTE: For application data, please see page Q11.

High-Performance High-Speed Steel (HSS-E/PM)