

- Centre cutting.
- Fine pitch.
- Standard items listed. Additional styles and coatings made-to-order.

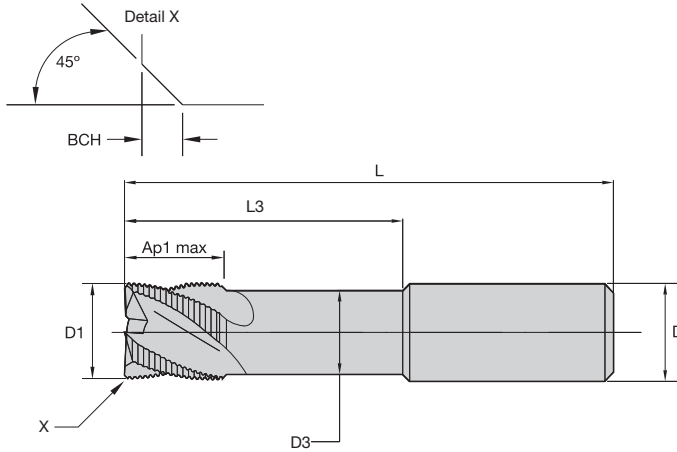

End Mill Tolerances

D1	tolerance	D	tolerance h6 + / -
All	+0,12/-0,12	≤ 3	0/0,006
		> 3-6	0/0,008
		> 6-10	0/0,009
		> 10-18	0/0,011
		> 18-30	0/0,013

■ Series 6NL6

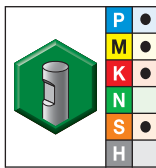

grade TiAlN-LW
TiAlN

- first choice
- alternate choice

order #	catalogue #	D1	D	D3	length of cut Ap1 max	L3	length L	BCH	ZU
1660617	6NL610004LW	10,0	10	10	22,00	69,00	110	0,25	4
1660623	6NL612005LW	12,0	12	12	26,00	78,00	125	0,35	4
1660629	6NL616006LW	16,0	16	15	32,00	87,00	138	0,35	4
1660635	6NL620007LW	20,0	20	20	38,00	108,00	160	0,35	4
1660640	6NL625008LW	25,0	25	25	45,00	155,00	216	0,50	5

NOTE: For application data, please see page Q11.

High-Performance High-Speed Steel (HSS-E/PM)