

Face Mills • SuperFeed™ Series

Tool Bodies • Face Mills



Face Mills

- Through coolant capability.
- +/- 3 micron axial adjustment range.
- Balanced design.
- Easy setup in a simple system design.
- Modified standards available.

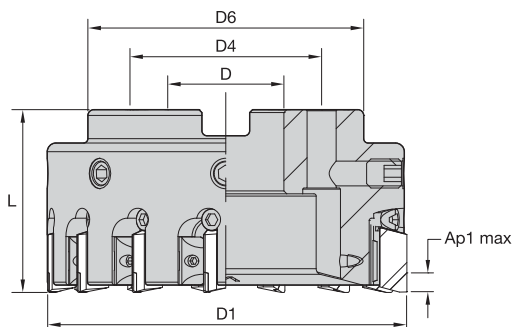
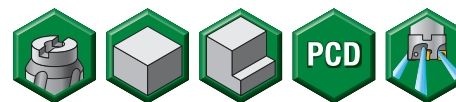

■ Face Mills • Metric

order number	catalogue number	D1	D	D4	D6	L	Ap1 max	Z	Z ADJ	kg	max RPM
5363208	SF06306RH	63	22	—	60	40	6	6	6	0,45	20000
5363209	SF08008RH	80	27	—	77	50	6	8	8	0,63	20000
5363220	SF10012RH	100	32	—	97	50	6	12	12	1,13	17320
5363221	SF12515RH	125	40	—	122	63	6	15	15	2,30	15500
5363222	SF16018RH	160	40	—	157	63	6	18	18	3,20	14150
5363223	SF20024RH	200	60	102	197	63	6	24	24	4,21	12240

NOTE: Z = Number of cartridges.
Z ADJ = Number of adjustable cartridges.

■ Spare Parts

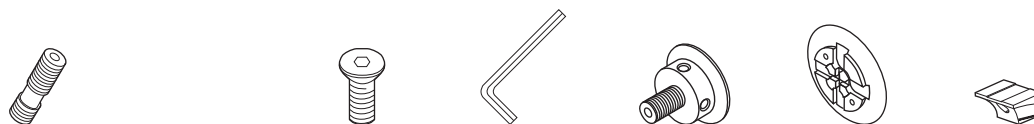

D1	wedge screw	wrench size wedge screw	adjusting screw	wrench size-adjusting screw	coolant cap	coolant shower plate	wedge
63	LS103	3 mm	SWSM515	4 mm	SALS063	—	HDWM5EU4DD
80	LS103	3 mm	SWSM515	4 mm	SALS080	—	HDWM5EU4DD
100	LS103	3 mm	SWSM515	4 mm	SALS100	—	HDWM5EU4DD
125	LS103	3 mm	SWSM515	4 mm	SALS125	—	HDWM5EU4DD
160	LS103	3 mm	SWSM515	4 mm	SALS160	—	HDWM5EU4DD
200	LS103	3 mm	SWSM515	4 mm	—	SSP8	HDWM5EU4DD

NOTE: Coolant cap or coolant shower plate must be ordered separately.

