

- Through coolant capability.
- +/- 3 micron axial adjustment range.
- Easy setup in a simple system design.
- Modified standards available.

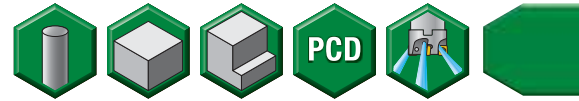

Face Mills

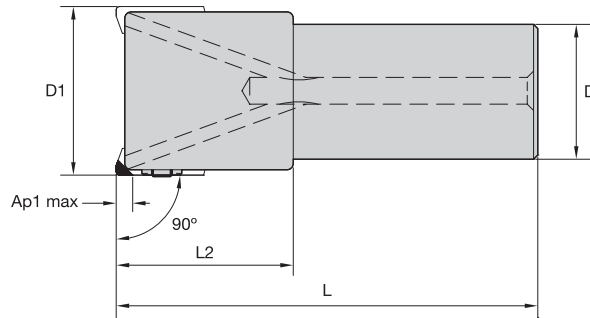

### ■ End Mills • Metric

order number	catalogue number	D1	D	L2	L	Ap1 max	Z	Z ADJ	kg	max RPM
5363252	WSSEM02502RH	25	20	40	100	6,4	2	2	0,22	35800
5363253	WSSEM03203RH	32	32	42	100	6,4	3	3	0,54	31600
5363254	WSSEM04004RH	40	32	42	100	6,4	4	4	0,49	28300
5363255	WSSEM05005RH	50	32	42	100	6,4	5	5	0,79	25300

NOTE: Z = Number of cartridges.  
Z ADJ = Number of adjustable cartridges.

### ■ Spare Parts

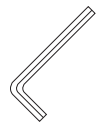

D1	wedge screw	wrench size wedge screw	wedge	adjusting screw	wrench size-adjusting screw
25	DSM550	3 mm	HDWM5S	SWSM5155	4 mm
32	DSM550	3 mm	HDWM5S	SWSM5155	4 mm
40	DSM550	3 mm	HDWM5S	SWSM5155	4 mm
50	DSM550	3 mm	HDWM5S	SWSM5155	4 mm

NOTE: For setting procedure, see page H68.