

Roughing and Finishing with a Single Tool •

WIDIA™ M4000

M4000

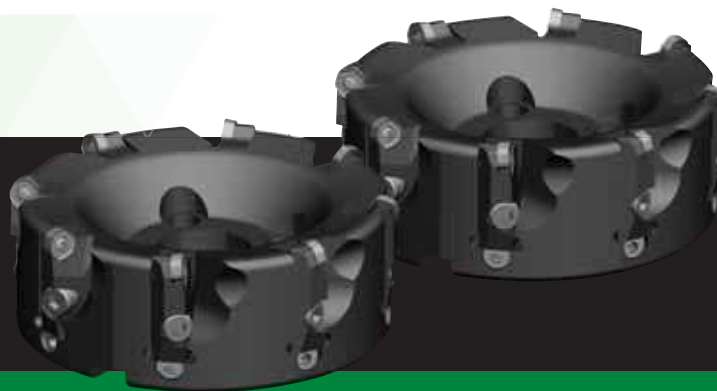

Cartridges with different insert styles and lead angles can be easily changed.

- Roughing and finishing solution with a single tool.
- Adjustable pockets and cartridge stop feature.
- Easily change cartridges with different insert styles and lead angles.
- Best-in-class flexibility lowers cost per tool.
- Easy runout adjustment.
- Perfect floor surface for finishing operations.

Roughing and Finishing with a Single Tool

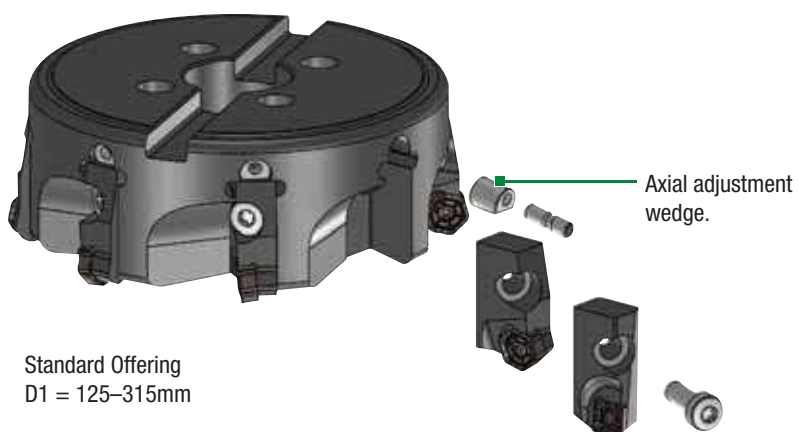

Standard Offering
D1 = 125–315mm

Quick cartridge stop — ready to go in a minute with no adjustment for roughing.

