

Slotting Mills • M94 Series

Weldon® Shanks

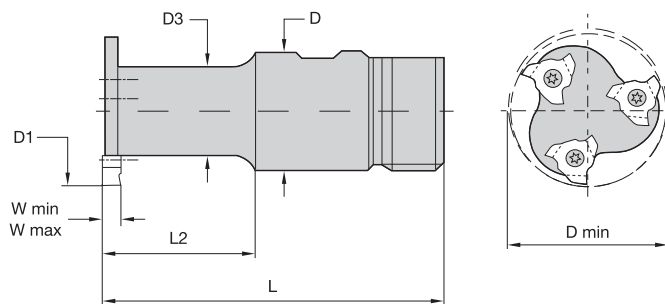

- Three cutting edges per insert.
- Tangential mounted inserts.
- Shallow grooving and slotting.

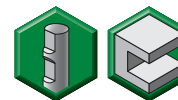

Weldon Shanks

order number	catalogue number	D1	D	D3	D min	L	L2	W min	W max	Z	insert 1	coolant supply	kg
2022619	12290900800	25	25	21	34	100	44	1,93	2,73	3	TCAX1103ZZ..	No	0,4
2022620	12290901200	40	32	32	65	110	50	2,73	4,26	3	TNAX1604ZZ..	No	0,7

NOTE: D min = minimum internal hole diameter required for clearance.

Spare Parts



insert screw



Nm



Torx driver

D1	insert screw	Nm	Torx driver
25	12148080000	1,0	12148086600
40	12148067200	3,5	12148086600

Slotting Mills