

Copy Mills • M200™ Series

iC10 • Screw-On End Mills

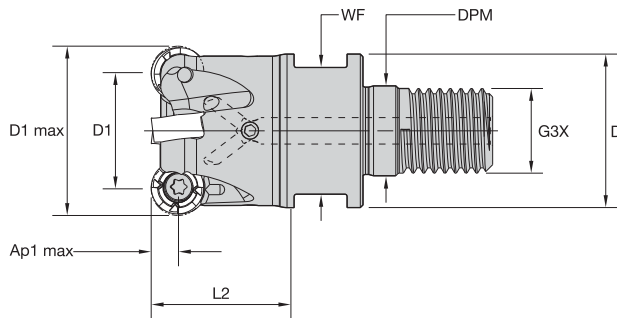

- Double-sided, eight cutting edges.
- Anti-rotation feature for better stability and higher feed rates.
- Pocketing and profiling capabilities.

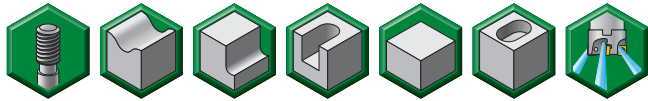

■ Screw-On End Mills

order number	catalogue number	D1 max	D1	D	DPM	G3X	L2	WF	Ap1 max	Z	max RPM	coolant supply	kg
5210273	M200D25Z03M12RN10	25	15	21	12,5	M12	32	17	5,0	3	54700	Yes	0,08
5210274	M200D32Z04M16RN10	32	22	29	17,0	M16	40	24	5,0	4	48300	Yes	0,18
5210275	M200D35Z05M16RN10	35	24	29	17,0	M16	40	24	5,0	5	46200	Yes	0,20
5210276	M200D42Z06M16RN10	42	32	29	17,0	M16	40	24	5,0	6	42200	Yes	0,24

■ Spare Parts



insert screw

191.848



Nm

2,0



Torx driver

170.025

Copy Mills