

- Double-sided, eight cutting edges.
- Anti-rotation feature for better stability and higher feed rates.
- Pocketing and profiling capabilities.

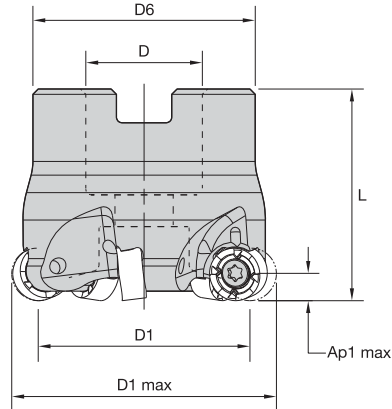

■ Shell Mills

order number	catalogue number	D1 max	D1	D	D6	L	Ap1 max	Z	max RPM	coolant supply	kg
5210305	M200D40Z04RN10	40	30	16	38	40	5,0	4	43200	Yes	0,23
5210306	M200D40Z06RN10	40	30	16	38	40	5,0	6	43200	Yes	0,24
5210307	M200D50Z05RN10	50	40	22	42	40	5,0	5	38600	Yes	0,32
5210308	M200D50Z06RN10	50	40	22	42	40	5,0	6	38600	Yes	0,32
5210309	M200D52Z06RN10	52	42	22	49	50	5,0	6	37900	Yes	0,52

■ Spare Parts

D1 max	insert screw	Nm	wrench	socket-head cap screw	socket-head cap screw with coolant groove
40	191.848	2,0	170.025	MS1294	MS1294CG
50	191.848	2,0	170.025	MS1234	MS1234CG
52	191.848	2,0	170.025	MS1242	MS1242CG

NOTE: Socket-head cap screw and socket-head cap screw with coolant groove must be ordered separately.

Copy Mills