

- Premium nickel-coated bodies.
- Designed for maximum performance.
- Ideally suited for die and mould manufacturing.

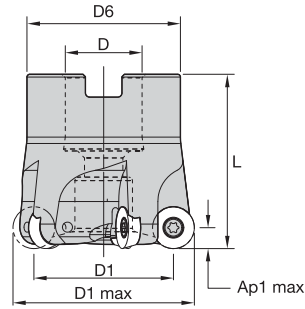
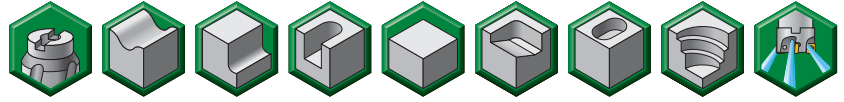

■ Shell Mills

order number	catalogue number	D1 max	D1	D	D6	L	Ap1 max	Z	max ramp angle	max RPM	coolant supply	kg
3926602	M170D050Z04RD16	50	34	22	44	40	8,0	4	8.5°	7900	Yes	0,28
3934623	M170D052Z04RD16	52	36	22	44	50	8,0	4	8.2°	7650	Yes	0,36
3934624	M170D063Z05RD16	63	47	22	44	40	8,0	5	5.5°	5300	Yes	0,39
3934625	M170D066Z05RD16	66	50	27	60	50	8,0	5	4.0°	6000	Yes	0,74
3934626	M170D080Z06RD16	80	64	27	60	50	8,0	6	3.0°	4900	Yes	1,06
3934628	M170D100Z07RD16	100	84	32	80	55	8,0	7	2.4°	3950	Yes	1,94
3934629	M170D125Z08RD16	125	109	40	90	60	8,0	8	2.2°	3200	Yes	2,90

Copy Mills

■ Spare Parts

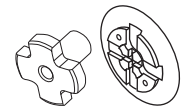

D1 max	insert screw	Nm	clamp screw	Torx driver	low-head cap screw	low-head cap screw with coolant groove	socket-head cap screw	socket-head cap screw with coolant groove	coolant lock screw	coolant cap
50	193.343	6,0	193.383 12148099400		129.025	—	—	MS2072CG	—	—
52	193.343	6,0	193.383 12148099400		129.025	—	—	MS2072CG	—	—
63	193.343	6,0	193.383 12148099400		129.025	—	—	MS2072CG	—	—
66	193.343	6,0	193.383 12148099400		—	—	MS2038	MS2038CG	—	—
80	193.343	6,0	193.383 12148099400		—	—	MS2038	MS2038CG	—	—
100	193.343	6,0	193.383 12148099400		MS1254	MS1254CG	—	—	—	—
125	193.343	6,0	193.383 12148099400		129.512	—	—	—	420.200	470.232

NOTE: All spare parts except the insert screws and clamp screws must be ordered separately.